

ECOTRAY



ECOTRAY prevents potential leaks from Hydraulic systems dripping onto floors and other internal components. The Skyjack system removes the need for a cumbersome, unsightly “diaper” and is particularly suited for working on sensitive areas, such as decorative flooring, clean rooms and areas where hygiene and concern for chemical contamination are a priority. Unlike other systems that focus on the main hydraulic tray, **ECOTRAY** also protects against leaks from hydraulic drive motors and lifting and steering cylinders when fitted.

Skyjack’s **ECOTRAY** has been designed with essential machine functionality in mind.

Essential functions not compromised include:

- Pothole protection
- Static strap use
- Access to the emergency stop
- Emergency lowering
- Base controls



ECOTRAY

VERTICAL MAST LIFTS

DC SCISSOR LIFTS

E SERIES DC SCISSOR LIFTS*

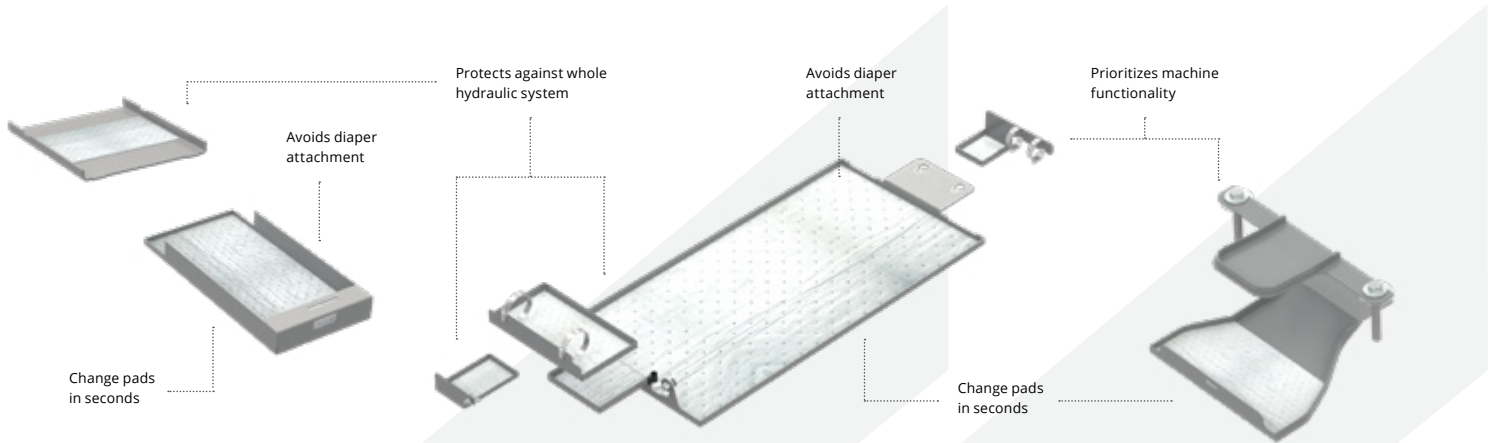

KEY FEATURES

- Protects against the whole hydraulic system, not just the main hydraulic tray.
- Avoids cumbersome diaper attachment
- Prioritizes machine functionality
- Protected from jobsite debris damage, forklift handling, etc.
- Available as a factory fit or field install option
- Installed in less than 10 minutes
- Absorbent pads changed in seconds

COMPATIBLE MODELS

| | |
|-------------------|---|
| SJ12 E | ✓ |
| SJ16 E | ✓ |
| SJ20 E | ✓ |
| SJ3215 & SJ3215 E | ✓ |
| SJ3219 & SJ3219 E | ✓ |
| SJ3220 E | ✓ |
| SJ3226 & SJ3226 E | ✓ |
| SJ4726 & SJ4726 E | ✓ |
| SJ4732 & SJ4732 E | ✓ |
| SJ4740 & SJ4740 E | ✓ |

*Illustrative purposes only; tray arrangement varies between E Series models

Skyjack Head Office

55 Campbell Rd.
Guelph, ON Canada N1H 1B9
Sales Inquiries: 1-877-755-4387 (1-877-SJLIFTS)
Main Switchboard: 1-800-265-2738
Phone: 519-837-0888
Fax: 519-837-8104
Email: skyjack@skyjack.com

Skyjack Parts & Service

2525 Enterprise Circle
West Chicago, IL 60185 USA
Phone: 630-262-0005
Toll Free: 1-800-275-9522
Fax: 630-262-0006
Email: service@skyjack.com

ACCESSORYZERS™
www.skyjack.com/accessoryzers