



SJIII 4740

ELECTRIC SCISSOR LIFT

STANDARD FEATURES

- SKYCODED™ colour coded and numbered wiring system
- Drivable at full height
- Variable speed, front 2 wheel hydraulic drive
- Wet disc SAHR brakes
- Proportional controls for drive & lift functions
- 0.90 m Roll out extension deck
- 24V DC Power source
- Low voltage battery protection
- 25% Gradeability
- Solid rubber, non-marking tyres
- Pothole protection system
- Wiring for AC outlet on platform
- Tilt alarm with drive & lift cut-out
- All motion audible alarm
- Overload sensing system
- Lowering warning system
- Lanyard attachment points
- Operator horn
- Flashing light
- Half height spring hinged gate
- Hinged railing system
- Forklift pockets and tie down/lift lugs
- Relay based control system
- Telematics ready

ACCESSORIES AND OPTIONS

- Dual flashing lights
- AGM Batteries
- Full height spring hinged gate
- Drywall/board carrier
- Heavy duty pipe rack
- Board/drywall carrier
- Tool caddy
- Secondary Guarding Lift Enable (SGLE)
- ELEVATE telematics

† Standard lead times may be increased when optional equipment is added, consult factory.

‡ Capacities, and machine weights may differ when options are added.

SJIII 4740 ELECTRIC SCISSOR LIFT

Dimensions	SJIII 4740
A Work Height	13.80 m
B Raised Platform Height	11.80 m
C Lowered Platform Height	1.37 m
D Overall Width	1.19 m
E Overall Length (Platform Retracted)	2.40 m
F Stowed Height (Rails Up)	2.49 m
G Stowed Height (Rails Down)	1.99 m
H Platform Width (Inside Railing)	1.06 m
I Platform Inside Length (Retracted)	2.19 m
Specifications	SJIII 4740
Extension Deck (Roll Out)	0.90 m
Ground Clearance (Pothole Raised)	8.10 cm
Ground Clearance (Pothole Deployed)	1.90 cm
Wheelbase	1.85 m
Weight	2,970 kg
Gradeability	25%
Turning Radius (Inside)	0.54 m
Turning Radius (Outside)	2.58 m
Lift Time (With Rated Load)	71 sec
Lowered Time (With Rated Load)	41 sec
Drive Speed (Stowed)	3.2 km/h
Drive Speed (Raised)	1.0 km/h
Maximum Drive Height	Full Height
Capacity (Overall)	350 kg
Maximum # of Persons (Indoor/Outdoor)	3/0
Tyre Type	Solid, N/M
Tyre Size	16 x 5 x 12

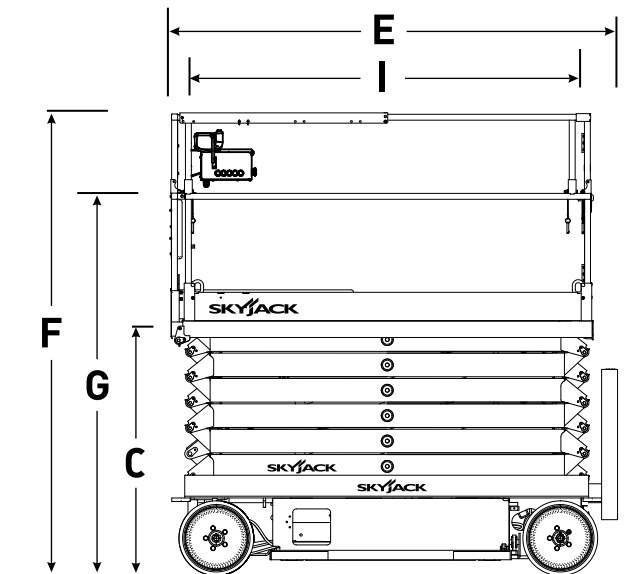
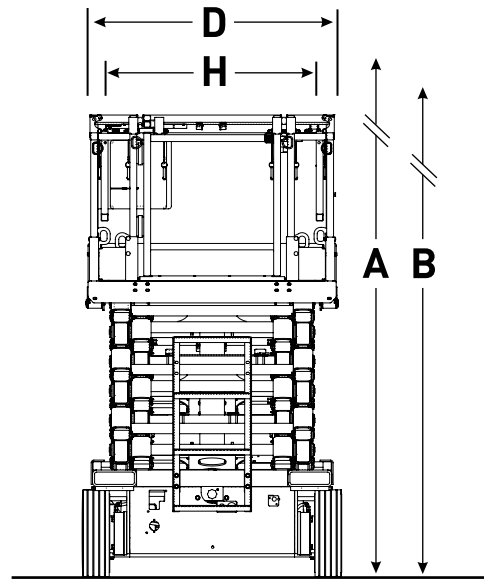

Skyjack Australia Pty Ltd
 Unit 1, 35 Honeycomb Drive
 Eastern Creek
 NSW 2766
 Australia
 Phone +61 (0) 2 9854 0700
 Fax +61 (0) 2 9854 0777
 Email: jcranmer@skyjack.com

www.skyjack.com

This brochure is for illustrative purpose only and based on the latest information at the time of printing. Skyjack Inc. reserves the right to make changes at any time, without notice, to specifications, standard and optional equipment. Consult the Operating Maintenance and Parts Manuals for proper procedures. AS marked platforms are in conformance to Standard AS/NZS 1418.10:2011.