

SJ3215/19 E

ELECTRIC SCISSORS



STANDARD FEATURES

- Drivable at full height
- Variable speed, dual front wheel electric drive
- 90° Steering (zero inside turning radius)
- AGM Batteries
- Dual holding brakes
- SKYCODED™ Colour coded and numbered wiring system
- On-board visual interface with diagnostic capabilities
- Shroud style, impact resistant composite control box with extended cable
- Proportional controls for drive & lift functions
- 0.91 m Roll out extension deck
- 24V DC Power source
- Low voltage battery protection
- 25% Gradeability
- Solid rubber, non-marking tyres
- Pothole protection system
- 12.5 m/s Wind rating
- Tilt alarm with drive & lift cut-out (3.5° x 1.5°)
- Lanyard attachment points
- Operator horn
- Forklift pockets and tie down / lift lugs
- Overload sensing system
- Solid rails
- Half height spring hinged entry gate
- Low battery indicator light on control box
- Flashing light
- White noise alarm
- All motion audible alarm
- Telematics ready
- 2-Year Gold Leaf Warranty (5-year structural warranty)



- 16% operational carbon saving compared to previous model



- Up to 20% improvement in duty cycle



- ZERO emissions



- <70 dB inherently quiet machine operation (excl. alarms)
- White noise/broadband alarms - *optional*



- 90% recyclable (by weight)



- 60% less hydraulic connections – reduces leak potential
- ECOTRAY leak containment - *optional*
- Bio-degradable hydraulic oil - *optional*



- Telematics – remote diagnostics reduces site visits (operational carbon footprint)

SJ3215/19 E ELECTRIC SCISSORS

Dimensions	SJ3215 E	SJ3219 E
A Work Height	6.44 m	7.65 m
B Raised Platform Height	4.44 m	5.65 m
C Lowered Platform Height	0.91 m	1.04 m
D Overall Width	0.82 m	0.82 m
E Overall Length	1.80 m	1.80 m
F Stowed Height (Rails Up)	1.88 m	1.99 m
G Platform Width (Inside Dimension)	0.66 m	0.66 m
H Platform Length (Inside Dimension)	1.55 m	1.55 m
Specifications	SJ3215 E	SJ3219 E
Extension Deck (Roll Out)	0.91 m	0.91 m
Ground Clearance (Pothole Raised)	8.9 cm	8.9 cm
Ground Clearance (Pothole Deployed)	1.3 cm	1.3 cm
Wheelbase	1.38 m	1.38 m
Weight	1,141 kg	1,468 kg
Gradeability	25%	25%
Turning Radius (Inside)	0	0
Turning Radius (Outside)	1.65 m	1.65 m
Lift Time (With Rated Load)	21 sec	22 sec
Lower time (With Rated Load)	18 sec	32 sec
Drive Speed (Stowed)	3.4 km/h	3.4 km/h
Drive Speed (Raised)	0.9 km/h	0.9 km/h
Maximum Drive Height	Full Height	Full Height
Capacity (Overall)	272 kg	227 kg
Distributed Capacity (Main Platform)	159 kg	113 kg
Distributed Capacity (Extension Deck)	113 kg	113 kg
Local Floor Load (With Rated Load)	1,093 kPa	1,159 kPa
Overall Floor Load (With Rated Load)	9.7 kPa	11.6 kPa
Maximum # of persons at 0 m/s wind rating	2	2
Maximum # of persons up to 12.5 m/s wind rating	1	1
Tyre Type	Solid, N/M	Solid, N/M
Tyre Size	12 x 4 x 8	12 x 4 x 8

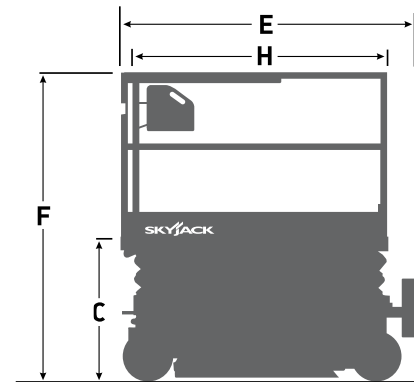
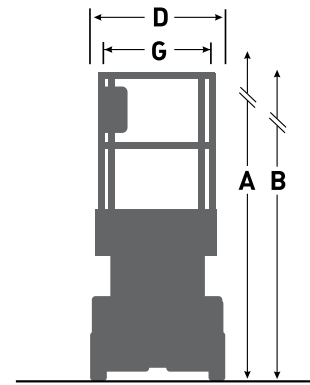

ACCESSORIES †

- Light duty pipe rack
- Heavy duty pipe rack
- Board carrier
- Tool caddy
- ECOTRAY leak containment system
- Secondary Guarding Lift Enable (SGLE)
- Perimeter lights (Cannot be combined with dual flashing lights)

OPTIONS †

- Dual flashing lights
- Lead acid batteries
- Lockable swingout trays
- Full height spring hinged entry gate
- Bio oil
- ELEVATE telematics (3-year or 5-year plans available)

† Standard lead times may be increased when optional equipment is added, consult factory.

‡ Capacities and machine weights may differ when accessories and options are added.

* Only available with ELEVATE telematics

Skyjack Australia Pty Ltd
 Unit 1, 35 Honeycomb Drive
 Eastern Creek
 NSW 2766
 Australia
 Phone +61 (0) 2 9854 0700
 Fax +61 (0) 2 9854 0777
 Email: jcranmer@skyjack.com

www.skyjack.com

SKYJACK
 simply reliable