



SJIII 4740

ELECTRIC SCISSOR LIFT

STANDARD FEATURES

- Drivable at full height with roll out deck fully extended
- Variable speed, front wheel hydraulic drive
- Flashing light
- DC Motor controller
- Dual holding brakes
- Proportional controls for drive & lift functions
- 0.90 m Roll out extension deck
- 24V DC power source
- Low voltage battery protection
- Relay-based control system
- Colour coded and numbered wiring system
- 25% Gradeability
- Solid rubber, non-marking tyres
- Pothole protection system
- Wiring for AC outlet on platform
- Tilt alarm with drive & lift cut-out
- Overload sensing system
- Lowering warning system
- Operator horn
- Half height spring hinged gate
- Hinged railing system
- Lanyard attachment points
- Forklift pockets and tie down/lift lugs

ACCESSORIES AND OPTIONS

- All motion audible alarm
- Dual flashing lights
- AGM Batteries
- Drywall/board carrier
- Heavy duty pipe rack
- Secondary Guarding Lift Enable (SGLE)
- ELEVATE telematics

† Standard lead times may be increased when optional equipment is added, consult factory.

‡ Capacities, and machine weights may differ when options are added.

SJIII 4740 ELECTRIC SCISSOR LIFT

Dimensions	SJIII 4740
A Work Height	13.80 m
B Raised Platform Height	11.80 m
C Lowered Platform Height	1.37 m
D Overall Width	1.19 m
E Overall Length (Platform Retracted)	2.40 m
F Stowed Height (Rails Up)	2.49 m
G Stowed Height (Rails Down)	1.99 m
H Platform Width (Inside Railing)	1.06 m
I Platform Inside Length (Retracted)	2.19 m
Specifications	SJIII 4740
Extension Deck (Roll Out)	0.90 m
Ground Clearance (Pothole Raised)	8.10 cm
Ground Clearance (Pothole Deployed)	1.90 cm
Wheelbase	1.85 m
Weight	2985 kg
Gradeability	25%
Turning Radius (Inside)	0.54 m
Turning Radius (Outside)	2.58 m
Lift Time (With Rated Load)	71 sec
Lowered Time (With Rated Load)	41 sec
Drive Speed (Stowed)	3.2 km/h
Drive Speed (Raised)	1.0 km/h
Maximum Drive Height	Full Height
Capacity (Overall)	350 kg
Maximum # of Persons (Indoor/Outdoor)	3/0
Tire Type	Solid, N/M
Tire Size	16 x 5 x 12

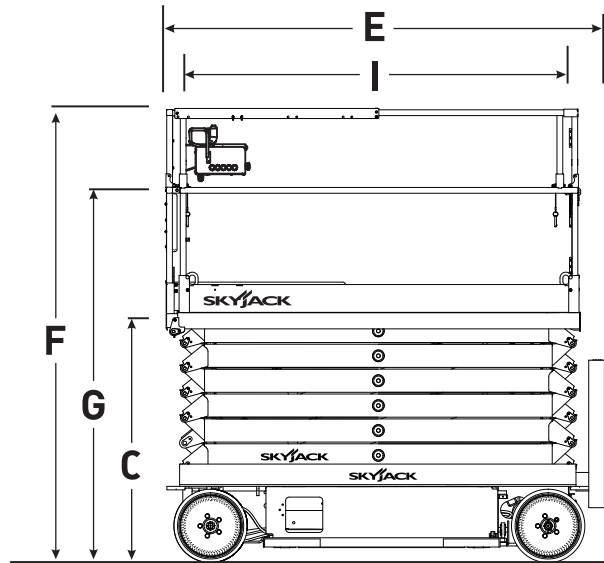
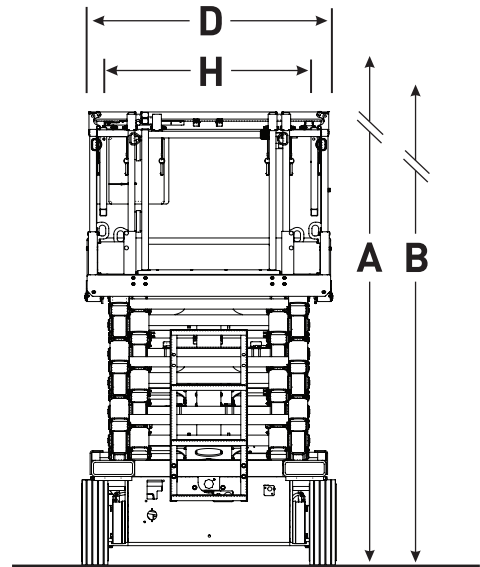

Skyjack UK
 Unit 1, Maes-y-Clawdd
 Maesbury Road Industrial Estate
 Oswestry, Shropshire, SY10 8NN
 Tel: +44 (0) 1691 676235
 Fax: +44 (0) 1691 676239
 Email: info@skyjackeurope.co.uk

Skyjack France
 74 Rue Sibert
 F-42400 Saint-Chamond
 France
 Tel. +33 (0) 4 78 73 53 32
 Fax. +33 (0) 4 78 56 52 42

Skyjack Germany
 Därmannsbusch 2a
 D-58456 Witten
 Germany
 Tel: +49 (0) 2302 20 26 909
 Fax: +49 (0) 2302 20 25 671

Skyjack AB Sweden
 Agnesbergsvägen 28
 424 38 Agnesberg
 Sweden
 Tel: +46 (0) 31 21 22 45
 Fax: +46 (0) 31 787 65 10

www.skyjack.com