

SJ4726/32 E

ELECTRIC SCISSORS



STANDARD FEATURES

- Drivable at full height
- Variable speed, dual rear wheel electric drive
- Dual holding brakes
- SKYCODED™ Color coded and numbered wiring system
- On-board visual interface with diagnostic capabilities
- Shroud style, impact resistant composite control box with extended cable
- Low battery indicator light on control box
- Proportional controls for drive & lift functions
- 4' (1.2 m) Roll out extension deck
- 24V DC Power source
- Low voltage battery protection
- 25% Gradeability
- Solid rubber, non-marking tires
- Pothole protection system
- Tilt alarm with drive & lift cut-out (3.5° x 1.5°)
- All motion audible alarm
- 28 mph (12.5 m/s) Wind rating
- Lanyard attachment points
- Operator horn
- Forklift pockets and tie down / lift lugs
- Overload sensing system
- Fold down hinged railing system
- Half height spring hinged entry gate
- Telematics ready
- 2-Year Gold Leaf Warranty (5-year structural warranty)



- 16% operational carbon saving compared to previous model



- Up to 20% improvement in duty cycle



- ZERO emissions



- <70 dB inherently quiet machine operation (excl. alarms)
- White noise/broadband alarms - *optional*



- 90% recyclable (by weight)



- 60% less hydraulic connections – reduces leak potential
- ECOTRAY leak containment - *optional*
- Bio-degradeable hydraulic oil - *optional*



- Telematics – remote diagnostics reduces site visits (operational carbon foot print)

SJ4726/32 E ELECTRIC SCISSORS

Dimensions	SJ4726 E	SJ4732 E
A Work Height	31' 8" (9.65 m)	37' 8" (11.48 m)
B Raised Platform Height	25' 8" (7.82 m)	31' 8" (9.65 m)
C Lowered Platform Height	46" (1.17 m)	50" (1.27 m)
D Overall Width	47" (1.20 m)	47" (1.20 m)
E Overall Length	91.6" (2.32 m)	91.6" (2.32 m)
F Stowed Height (Rails Up)	90" (2.29 m)	94" (2.39 m)
G Stowed Height (Rails Down)	75" (1.90 m)	78.5" (1.99 m)
H Platform Width (Inside Dimension)	42" (1.07 m)	42" (1.07 m)
I Platform Length (Inside Dimension)	83" (2.11 m)	83" (2.11 m)
Specifications	SJ4726 E	SJ4732 E
Extension Deck (Roll Out)	4' (1.22 m)	4' (1.22 m)
Ground Clearance (Pothole Raised)	4.0" (10.2 cm)	4.0" (10.2 cm)
Ground Clearance (Pothole Deployed)	0.5" (1.3 cm)	0.5" (1.3 cm)
Wheelbase	69" (1.75 m)	69" (1.75 m)
Weight	4,362 lbs (1,979 kg)	5,478 lbs (2,485 kg)
Gradeability	25%	25%
Turning Radius (Inside)	28" (0.71 m)	28" (0.71 m)
Turning Radius (Outside)	104" (2.64 m)	104" (2.64 m)
Lift Time (With Rated Load)	60 sec	64 sec
Lower time (With Rated Load)	43 sec	41 sec
Drive Speed (Stowed)	2.1 mph (3.4 km/h)	2.1 mph (3.4 km/h)
Drive Speed (Raised)	0.6 mph (1.0 km/h)	0.6 mph (1.0 km/h)
Maximum Drive Height	Full Height	Full Height
Capacity (Overall)	1,000 lbs (454 kg)	700 lbs (318 kg)
Distributed Capacity (Main Platform)	700 lbs (318 kg)	450 lbs (204 kg)
Distributed Capacity (Extension Deck)	300 lbs (136 kg)	250 lbs (113 kg)
Local Floor Load (With Rated Load)	119 psi (820 kPa)	124 psi (856 kPa)
Overall Floor Load (With Rated Load)	178 psf (869 kg/m ²)	205 psf (1,001 kg/m ²)
Maximum # of persons at 0 mph (0 m/s) wind rating	3	2
Maximum # of persons up to 28 mph (12.5 m/s) wind rating	1	1
Tire Type	Solid, N/M	Solid, N/M
Tire Size	16 x 5 x 12	16 x 5 x 12

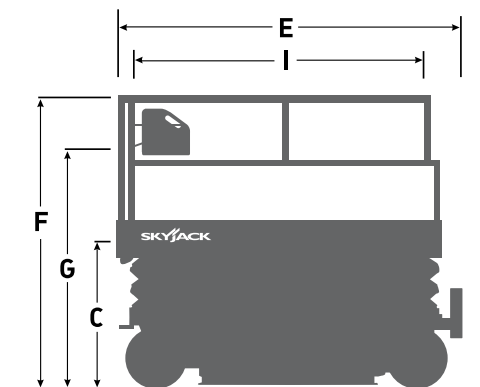
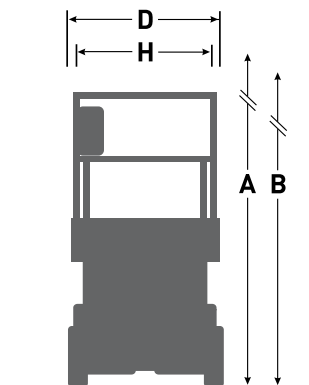

ACCESSORYZERS †

- Light duty pipe rack
- Heavy duty pipe rack
- Board carrier
- Tool caddy
- ECOTRAY leak containment system
- Secondary Guarding Lift Enable (SGLE)
- Perimeter lights (Cannot be combined with dual flashing lights)

OPTIONS †

- Flashing light
- Dual flashing lights
- White noise alarm
- 110V AC Outlet on platform with GFI
- 250 Ah Batteries
- AGM Batteries
- Lockable swingout trays
- EE Rating package
(Cannot be combined with telematics keypad, 250 Ah or AGM batteries, single or dual flashing lights, AC power on platform, perimeter lights, white noise alarm or ECOTRAY)
- Full height spring hinged entry gate
- Bio oil
- Non-destructive testing
- ELEVATE telematics (1-year, 3-year or 5-year plans available)
- Extended warranty (3-year or 5-year plans available)

Skyjack Head Office

55 Campbell Rd. Guelph, ON Canada N1H 1B9
 Sales Inquiries: 1-877-755-4387 (1-877-SJLIFTS)
 Main Switchboard: 1-800-265-2738
 Phone: 519-837-0888
 Fax: 519-837-8104
 Email: skyjack@skyjack.com

www.skyjack.com

† Standard lead times may be increased when optional equipment is added, consult factory.
 ‡ Capacities and machine weights may differ when accessories and options are added.

