

SJ3213/19 micro

ELECTRIC SCISSORS



STANDARD FEATURES

- Drivable at full height
- Variable speed, dual front wheel electric drive
- Motor guards
- Dual holding brakes
- SKYCODED™ Color coded and numbered wiring system
- On-board visual interface with diagnostic capabilities
- Shroud style, impact resistant composite control box with extended cable
- Low battery indicator light on control box
- Proportional controls for drive & lift functions
- 20" (0.5 m) Roll out extension deck
- 24V DC Power source
- 2 x 12V Batteries
- Low voltage battery protection
- 25% Gradeability
- Solid rubber, non-marking tires
- Fixed pothole protection system
- Tilt alarm with drive & lift cut-out (3° x 1.5°)
- All motion audible alarm
- Lanyard attachment points
- Operator horn
- Forklift pockets and tie down / lift lugs
- Overload sensing system
- Solid rails
- Full height spring hinged entry gate
- Telematics ready
- 2-Year Gold Leaf Warranty (5-year structural warranty)



- 12% overall carbon saving compared to traditional 19ft DC scissor



- ZERO emissions



- <70 dB inherently quiet machine operation (excl. alarms)
- White noise/broadband alarms - *optional*



- 90% recyclable (by weight)



- ECOTRAY leak containment - *optional*
- Bio-degradeable hydraulic oil - *approved*



- Telematics – remote diagnostics reduces site visits (operational carbon foot print)*

* Only available with ELEVATE telematics

SJ3213/19 micro ELECTRIC SCISSORS

Dimensions	SJ3213 micro	SJ3219 micro
A Work Height	19' (5.8 m)	24' 1" (7.3 m)
B Raised Platform Height (Indoor)	13' (3.96 m)	18' 1" (5.5 m)
C Raised Platform Height (Outdoor Optional)	12' (3.65 m)	16' (4.87 m)
D Lowered Platform Height	32" (0.81 m)	36" (0.91 m)
E Overall Width	32" (0.81 m)	32" (0.81 m)
F Overall Length	60" (1.5 m)	60" (1.5 m)
G Stowed Height (Rails Up)	75.8" (1.9 m)	79.5" (2.0 m)
H Platform Width (Outside Dimension)	27.5" (0.7 m)	27.5" (0.7 m)
I Platform Length (Outside Dimension)	60" (1.5 m)	60" (1.5 m)
Specifications	SJ3213 micro	SJ3219 micro
Extension Deck (Roll Out)	20" (0.5 m)	
Ground Clearance (Lowest Point)	1" (2.5 cm)	
Ground Clearance (Highest Point)	3.25" (8 cm)	
Wheelbase	49.5" (1.26 m)	
Weight	1,897 lbs (861 kg)	2,675 lbs (1,214 kg)
Gradeability	25%	
Turning Radius (Inside)	2.5" (6.4 cm)	
Turning Radius (Outside)	64.7" (1.64 m)	
Lift Time (With Rated Load)	25 sec	25 sec
Lower time (With Rated Load)	18 sec	26 sec
Drive Speed (Stowed)	2.1 mph (3.4 km/h)	
Drive Speed (Raised)	0.4 mph (0.6 km/h)	
Maximum Drive Height (Indoor)	Full Height	
Maximum Drive Height (Outdoor)	12' (3.65 m) (OPT)	16' (4.87 m) (OPT)
Capacity (Overall)	500 lbs (227 kg)	
Distributed Capacity (Extension Deck)	220 lbs (99.5 kg)	
Local Floor Load (With Rated Load)	152 psi (1,047 kPa)	175 psi (1,207 kPa)
Overall Floor Load (With Rated Load)	178 psf (8.5 kPa)	235 psf (11.3 kPa)
Maximum # of persons at 0 mph (0 m/s) wind rating	2	
Maximum # of persons up to 28 mph (12.5 m/s) wind rating	Optional 1	
Tire Type	Solid, N/M	
Tire Size	10 x 4	

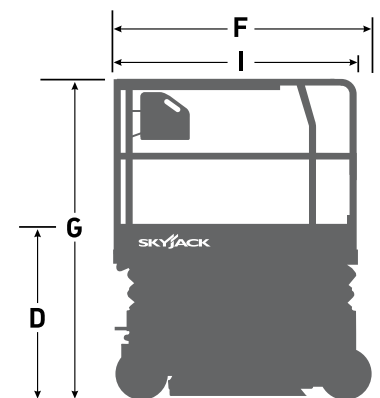
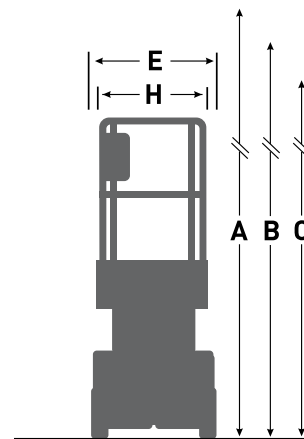

ACCESSORYZERS †

- ECOTRAY leak containment system
- Secondary Guarding Lift Enable (SGLE)
- Perimeter lights

OPTIONS †

- Dual flashing lights
- AGM Battery option
- 28 mph (12.5 m/s) Wind rating
Up to 12' (3.65 m) for SJ3213 micro and 16' (4.87 m) for SJ3219 micro
- White noise alarm
- 110V AC Outlet on platform with GFI
- AGM Batteries
- Lockable swingout trays
- Non-destructive testing
- ELEVATE telematics (1-year, 3-year or 5-year plans available)
- Extended warranty (3-year or 5-year plans available)

Skyjack Head Office

55 Campbell Rd. Guelph, ON Canada N1H 1B9
 Sales Inquiries: 1-877-755-4387 (1-877-SJLIFTS)
 Main Switchboard: 1-800-265-2738
 Phone: 519-837-0888
 Fax: 519-837-8104
 Email: skyjack@skyjack.com

www.skyjack.com

† Standard lead times may be increased when optional equipment is added, consult factory.
 ‡ Capacities and machine weights may differ when accessories and options are added.

SKYJACK
 simply reliable